

**Determination of Polychlorinated Biphenyl Congeners (PCBs)
and Organochlorine Pesticides (OCPs) in Fish Oil by Florisil
Cleanup and GC/MS/MS and ECD Analysis**

Ruud Addink and Tom Hall
Fluid Management Systems
Billerica MA

Introduction (1)

- Analysis of foodstuffs for PCBs and Organochlorine Pesticides is carried out by many labs around the world
- Simple single-column cleanup can increase turnover and reduce cost
- Florisil is a synthetic magnesium-silicate with a large surface area

Introduction (2)

- PCBs were intentionally produced 1920-1970s.
 - Used in capacitors and transformers, also as flame retardants, hydraulic fluids, sealants, and vacuum pump fluids.
 - Total production estimated worldwide 1.5 million metric tons. Produced as Aroclor in North-America.
 - Levels are now dropping.
 - Still at significant concentrations to pose danger.
- 

Introduction (3)

- Organochlorines have a wide range of both acute and chronic health effects
- Cancer
- Neurological effects
- Birth defects
- Many OCPs are also suspected endocrine disruptors

Semi-Automated Cleanup Approach

- Manual method is labor intensive, prone to error
- Certified 7.5 g Florisil can be used with very low native background. Consistent packing assures similar density between columns and reproducibility of cleanup. Teflon chips are added upstream of column material for processing tough samples.
- Fewer interferences in analysis
- Less glass ware and solvent use

Specification:

- Simple to run, no computerized instrumentation
 - Fast: 30 min
 - Closed loop system to give a clean background, low level detection
 - Use certified columns
 - One column per sample
 - No capital equipment cost
 - No electronics or mechanical equipment to fail
 - No downtime
- 

Semi-Automated System for Florisil

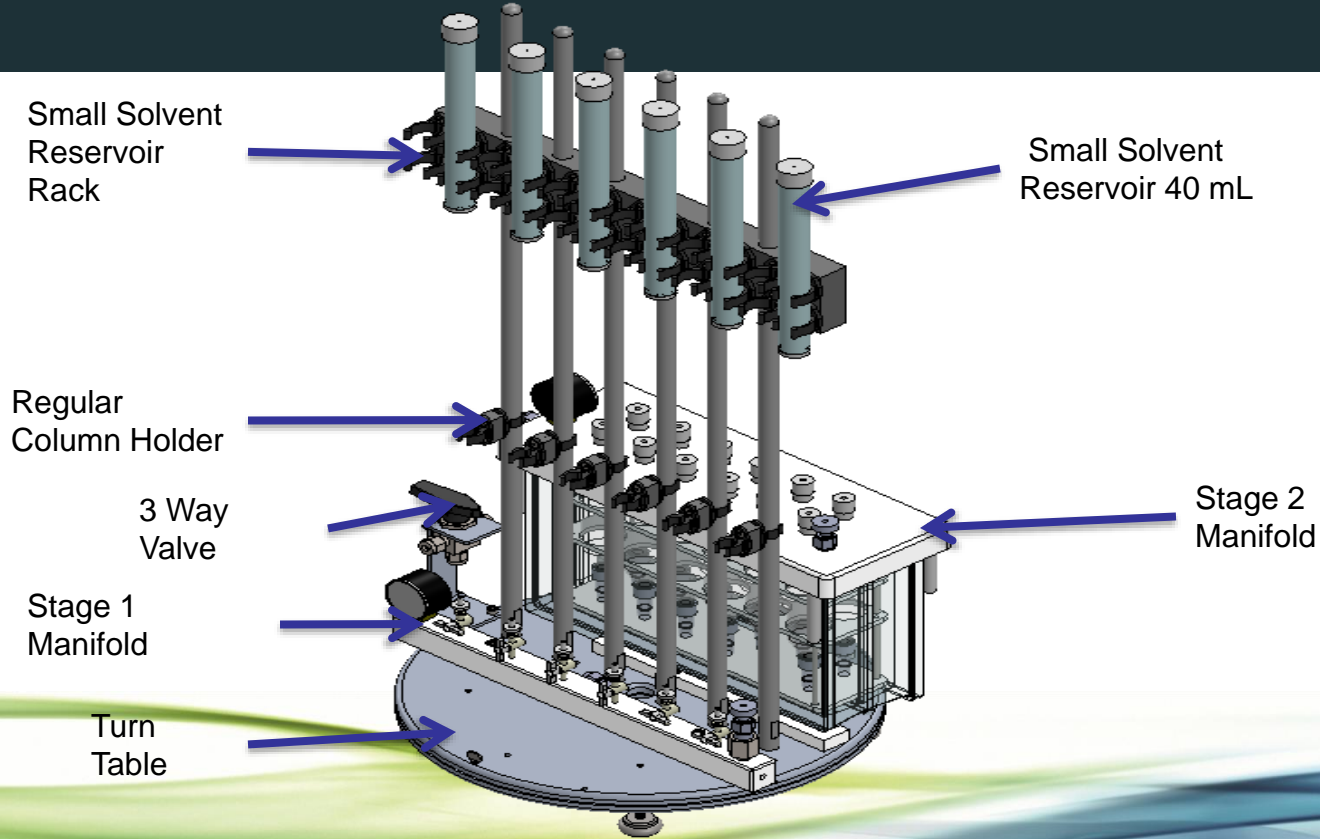

Stage 1 Manifold

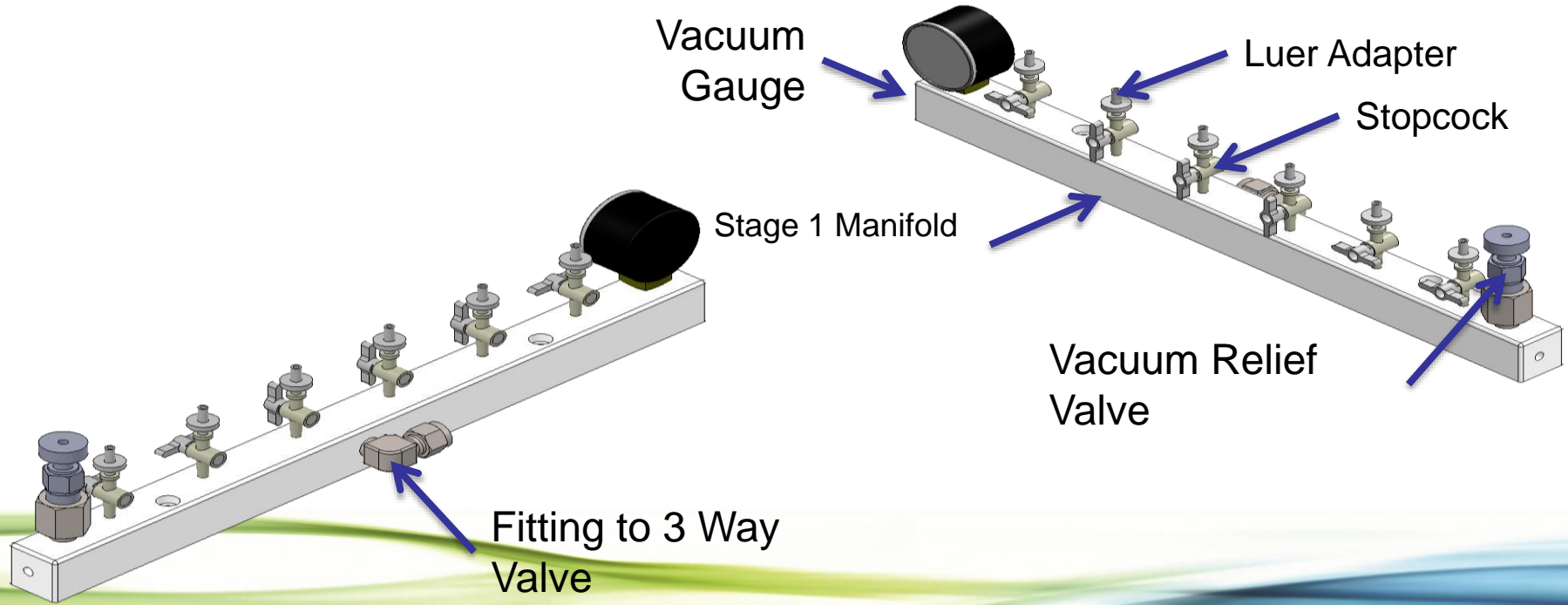

Stage 1 Manifold Transparent View

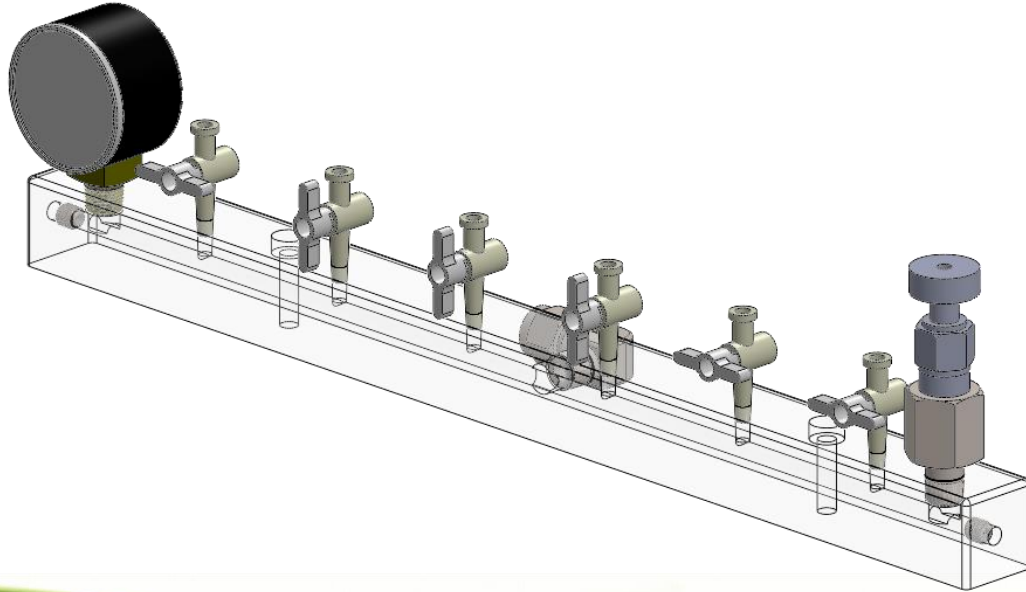

Florisil columns

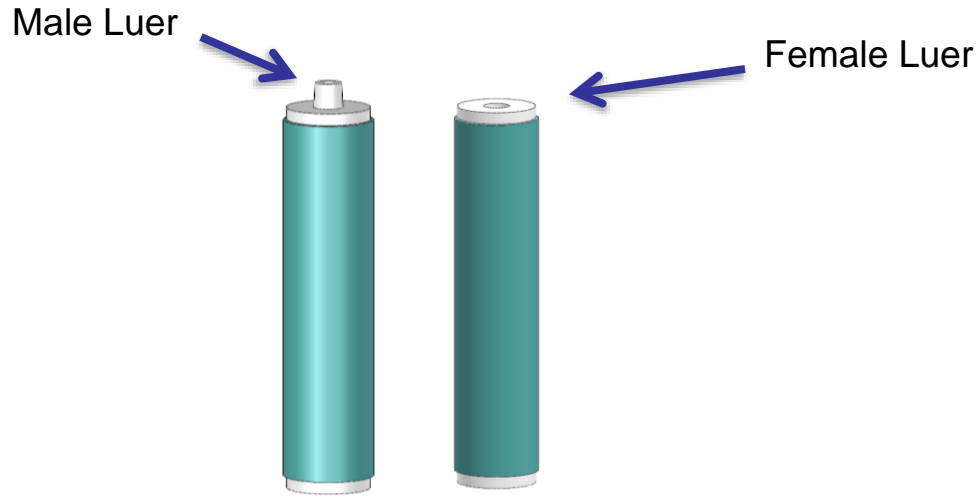

Flow thru system (Stage 1)

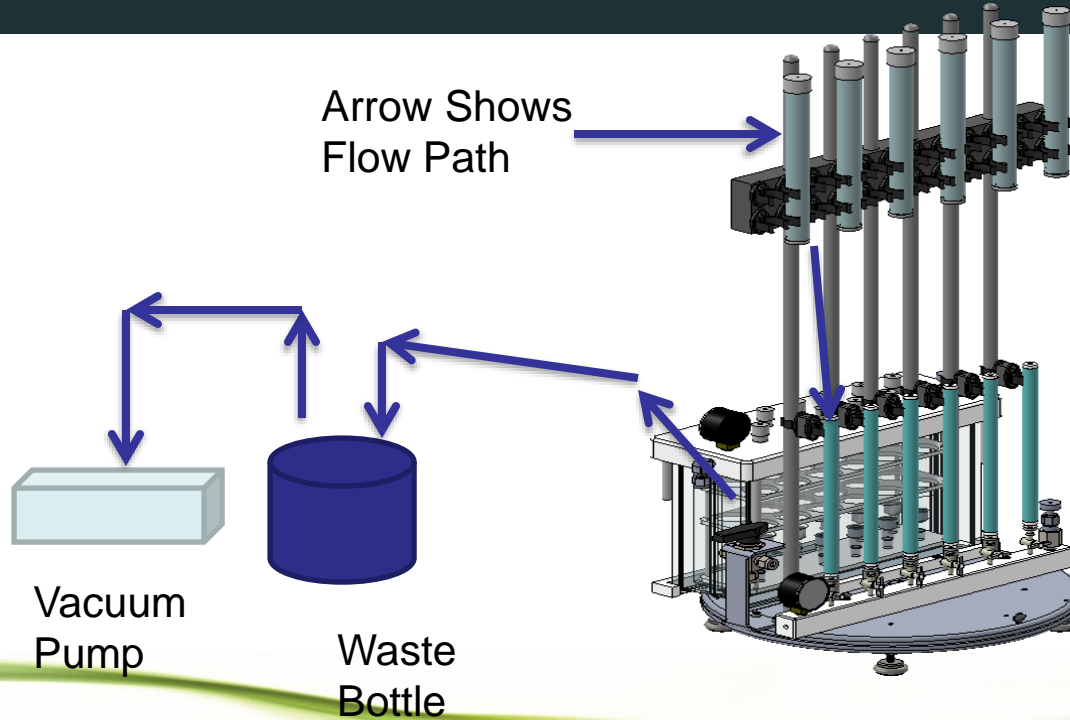

Collection (Stage 2)

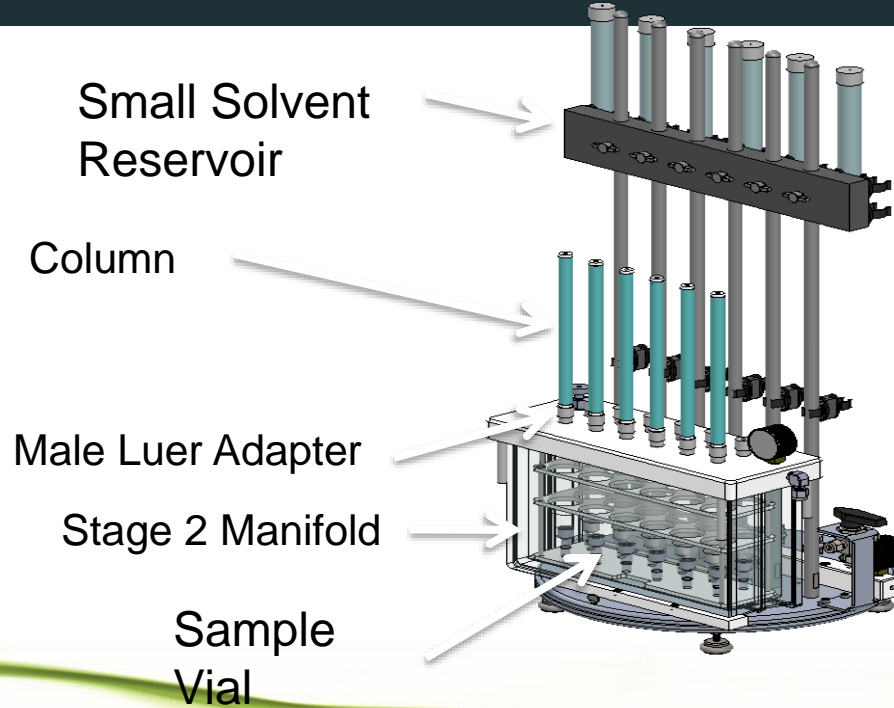

Procedure (1)

- Stage 1:
 - Assemble Florisil column with EZPrep set-up
 - Syringe vial at top is used for conditioning and sample loading
 - Condition silica column with 25 mL hexane (vacuum, waste)
 - Condition afterwards with 25 mL of 25% dichloromethane in hexane (vacuum, waste)
- 

Procedure (2)

- Stage 2:
- Samples in ~ 2 mL hexane
- Load sample extract onto Florisil column, rinse walls with 2 x 1 mL DCM/hexane
- Elute Florisil column with 25 mL of 25% DCM/hexane, collecting one fraction with all PCBs and OCPs

12 position evaporator 50 mLs



Evaporation and Analysis

- System pre-heated to 45 °C.
- Samples evaporated at stable T under 5-6 psi nitrogen.
- 2 mL extract transferred to 2 GC vials @ 1 mL extract each (can have direct-to-vial feature)
- Analyze OCPs on Agilent GC/ECD with 1 mL extract
- Analyze PCBs on Agilent 7010B GC/MS/MS reduce 1 mL extract to 50 uL

Direct-to-Vial



GC vial

Vial evaporator



Agilent 7010 GC-MS/MS



Experimental

- Run 1-2 g fish oil across 7.5 g Florisil columns
- Low fat samples (0.5 -1.5 g fat)
- Spike with 1 ug of OCPs
- Spike with 1 ng ¹³C PCBs

OCPs and fish oil

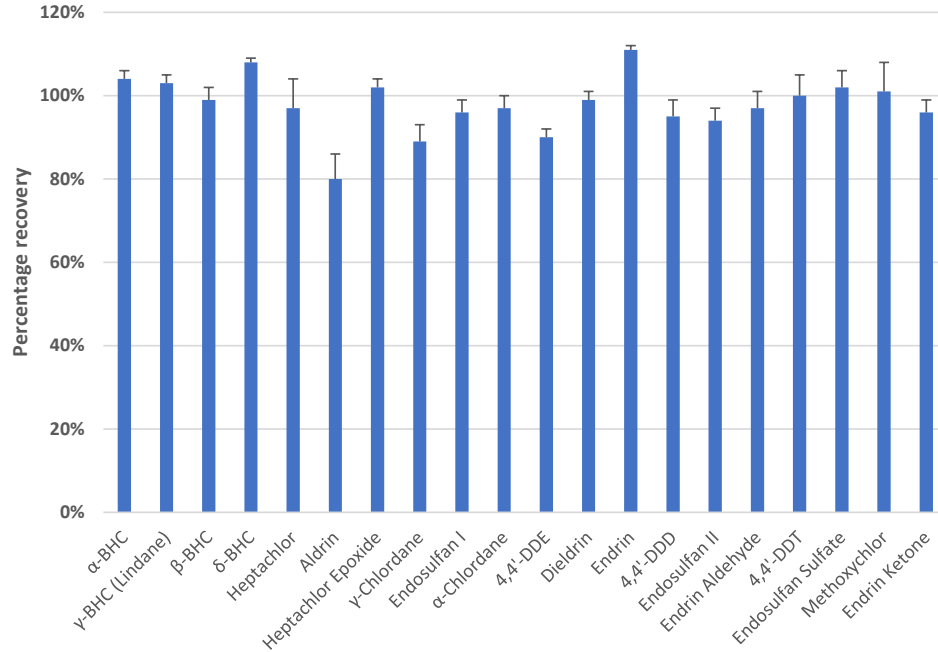

1 ug OCPs
across Florisil

PCBs and fish oil

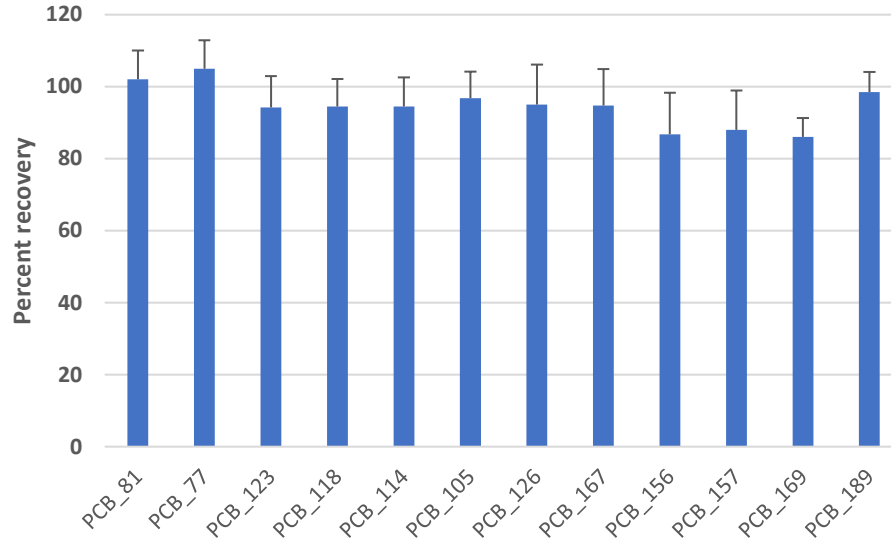

1 ng ^{13}C PCBs
across Florisil

Conclusions

- Semi-automated EZPrep can process 6 samples in parallel quickly using vacuum
- Excellent recoveries for OCPs and PCBs in low fat samples using single Florisil column
- Quick reliable technique approximately 30 min
- Inexpensive system can be used in hood or on lab bench
- Pre-packaged columns with very low native background
- Suitable for other matrices with low lipid, e.g., serum

Questions

- Questions?
- See us at Table # 45
- Email raddink@fms-inc.com
- thall@fms-inc.com